

# GREENE & GREENE: *A Mystery Table*

BY DARRELL PEART



While conducting research for a book, the author encounters a previously unknown table from the workshop of Peter & John Hall.

Editor's Note: The following material is supplemental to the information published in the November 2007 issue of *Popular Woodworking*, by Darrell Peart. The printed issue is available at [popularwoodworking.com/Nov07](http://popularwoodworking.com/Nov07). Additional pictures of the original table are also available on the web site.

## Templates for floating tenons

You will need to produce two routing templates for the legs and three routing templates for the rails and stretchers, as seen in the photo at right. Because these are for a one-time use, they can easily be made using MDF or scrap material from around the shop. Detailed drawings and information for building two of the templates is given below right. Draw from that information and the project drawings to construct the remaining templates. When making the other templates keep in mind that you will be using a  $\frac{3}{8}$ "-diameter bit and a  $\frac{3}{4}$ "-diameter template guide.

The "platform" of the templates will be made from three rippings of  $\frac{3}{4}$ " MDF – two outside rippings  $2\frac{5}{8}$ " wide and a center ripping  $\frac{3}{4}$ " wide. The center  $\frac{3}{4}$ " ripping establishes a space between the two outside pieces for the  $\frac{3}{4}$ " template guide to run in.

Cut enough MDF rippings to produce the five templates needed. Be careful when sizing the  $\frac{3}{4}$ " center piece – ideally it should just enough oversize (.005") to allow the template guide to move freely without slop. Dry-fit the platform pieces first and test a  $\frac{3}{4}$ " template guide for ease of movement.

Assemble the template platforms by arranging lengths of the  $\frac{3}{4}$ " MDF between the  $2\frac{5}{8}$ " pieces to produce the needed template guide openings. Attach the underside reference pieces with glue and a nail gun. (I am loath to use a nail gun on furniture itself but when making disposable jigs and templates they are great time savers).

Referring again to the drawing, and using a sharp pencil, layout all the mortises on the legs, rails and aprons. It is wise to add about  $\frac{1}{32}$ "- $\frac{1}{16}$ " (depending upon your level of confidence) length to the leg mortises. This will give you some maneuverability later on during the assembly process.

## Milling Spline Stock

Machine all the (working) spline material for the project at one time. Both the shelf and top splines are  $\frac{1}{4}$ " thick. The shelf spline is  $2\frac{7}{32}$ " wide and the spline for the top is  $3\frac{1}{32}$ " wide. The long grain goes with the width of the spline. Using your planer, run down enough material to the needed thickness – checking the actual spline groove for final dimension.

Be sure to check the spline thickness with an end that does not have planer snipe. Also, unless your planer is precisely set, the final



**Templates for Tenons.** MDF is used to make the templates for the loose tenons and splines. The router is fitted with a  $\frac{3}{4}$ " guide collar and a  $\frac{3}{8}$ "-diameter straight bit. Dry fit the template pieces before gluing to ensure that the collar will move easily in the opening.

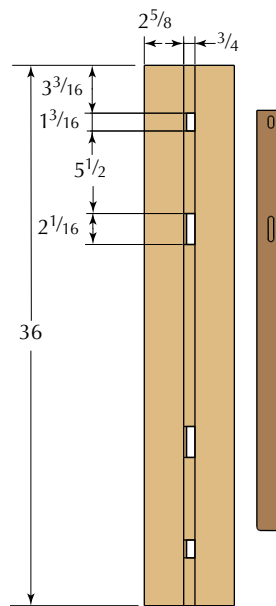

PLAN VIEW –  
JIG FOR MORTISES IN LEGS

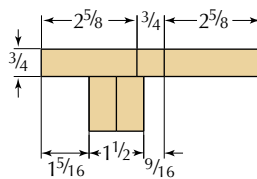

ELEVATION –  
JIG FOR MORTISES IN LEGS

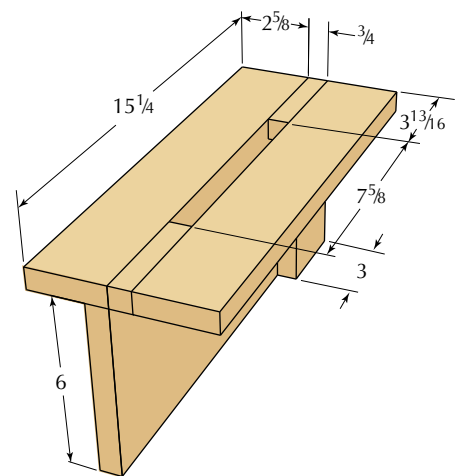

JIG FOR MORTISES IN  
ENDS OF SHELF & PANELS



**Routing results.** Each leg has short mortises for rails and long mortises for panels. Mark the legs on top with their orientation in the table.



**In position and in line.** After locating the plug holes and drilling with an undersized brad point bit, a small square is used to position the hollow mortiser chisel. The points of the chisel will mark the spot.



**Driving home the point.** The square chisel is placed back in position and hit with a hammer. After you reach the proper depth, use a small chisel to clean up the remaining waste.

thickness from side to side of the spline material will not be the same. To compensate for this: As you send the board through the planer, mark a point on the in-feed side of the planer. Note this spot in reference to the board on the final pass. Run the board one more time but turn the board so that the reference lines line up but the edges have switched sides.

This should produce a spline that is very

consistent in thickness. Crosscut the board to the width to produce the needed quantity of spines.

### Ebony Plug Holes

The ebony plug holes must be square, crisp and within close tolerance of size. Any tear-out or crushed wood around the perimeter of the hole will stand out in the finished piece.

One of the best and least complicated methods to produce the holes is by hand with the chisel from a hollow-chisel mortiser. To start the process, first mark all the locations of the holes (all four legs and the two shelf rails) with cross hairs. Drill each hole to a depth of  $\frac{3}{8}$ " with a brad-point bit  $\frac{1}{32}$ " less than the finished size of the plug. In other words, if you are working a  $\frac{1}{4}$ " plug hole, drill the center out with a  $\frac{7}{32}$ " bit.

Use a square to aid in positioning the hollow chisel squarely over the round hole as seen in the picture at left. Once it's positioned correctly, push the four points of the hollow chisel into the wood just enough so as to leave "re-positioning points." Now with hammer in hand, re-position the chisel in the points and chop out the square corners. Clean out any remaining debris with a normal chisel.

For the shelf-rail rectangles you will need to lay out the full rectangle in place and waste away as much of the hole as possible with the drill bit. Carefully line up the mortising chisel and "chop" to establish the corners at either end.

### Making and Inserting Ebony Plugs

Proud ebony plugs are an intrinsic part of Greene & Greene furniture. They are simple to produce but good results can be somewhat elusive at first. There is a tendency to make the face of the plugs too "pillowed." The way I will explain here is not the most efficient method – but it will yield good results with a little practice.

Mill out ebony stock in the form of long rods equal in thickness and width to the size



**Tenon for the dust panel.** A small piece of the plywood used for the dust panel is used as a loose tenon to hold the frame together.

of the plug holes. But instead of milling the rods to exact size, make them about .010"-.015" oversize (about  $\frac{1}{64}$ ") (the idea being that the harder and larger ebony plug will force its shape on the softer mahogany hole and leave a very crisp and well defined inlay).

With the rods milled, square up the ends. Find a soft, spongy surface such as foam-backed sandpaper. Place #120 grit sandpaper on top of the spongy surface and using a circular motion, swirl the end of rod on the sandpaper until you have a slightly pillowed face with even shoulders. Again do not "over-pillow" – less is more in this instance.

Hold the rod up to the light at different angles to check for inconsistencies in the face. Continue sanding up the grits to #400. On a buffing wheel, use white rouge to polish the face to a warm glow. Cut the polished end off the rod leaving about  $\frac{1}{4}$ " of length on the plug. Be sure the plugs are at least  $\frac{1}{16}$ " less in length than the plug holes are deep.

Next, using a sharp chisel slightly back-bevel the plug to aid its entry into the hole. To insert the plug use a plastic-headed mallet to gently tap it in place. Do not tap the plug past the shoulder of the pillowed face or it will lose definition. It is better to err on the side of leaving the plug slightly high. Resist that urge for one last tap!

## The Dust Panel

After milling the dust-panel rails to size (refer to the cut list), make two passes on the table saw to make the groove for the  $\frac{1}{4}$ "-plywood panel. Commercial plywood is usually a bit under thickness. The second pass on the saw should be adjusted to match the thickness of your ply.

Run the groove all the way through and use scrap from the  $\frac{1}{4}$ "-panel material for the dust panel's floating tenons. The two short rails will get a groove along their ends as well – to serve as mortises for the floating tenons.

This is a case where the exact position of the  $\frac{1}{4}$ " groove does not relate to or affect any other parts – so it is not necessary to fuss over it. Save your fussing for where it's needed. Also note that since the panel is plywood, it can and should be glued in the groove all the way around. When the machining is complete on the dust panel parts, glue it up.

## The Drawer

Drawers can be intimidating for a beginner, but they are really not that difficult if a little care is taken. This drawer is unusual in that it



**Positive Stop.** The kerf made by the dado cutters in the sled will position the workpiece and the stop accurately. After making the first cut, the board is flipped for the second.

does not have a back, but instead has two fronts and opens from either face of the table.

Before milling the drawer parts, verify their size by measuring the openings for the drawer fronts. There is a  $\frac{1}{16}$ " reveal around the drawer front so the overall size will be  $\frac{1}{8}$ " smaller than the opening. I find it helpful to first cut a scrap piece of MDF to properly fit the opening. Once the corrected size for the drawer is determined, mill out the  $\frac{13}{16}$ "-thick drawer fronts and  $\frac{1}{2}$ "-thick drawer sides along with plenty of scrap material.

To machine the finger joints we will be referencing off the middle, which means all the parts have to be precisely the same width.



**Test the fit.** Scrap material identical in size to the drawer parts is used to test the fit of the finger joints before milling the actual drawer parts.



**Perfect Match.** To make the matching cuts, the finger is lined up with the kerf in the sled, and the stop is slid into position.

If they are off the given dimension just a hair, that's OK – as long as they are all off precisely that same amount. The point is that all drawer parts must be consistently the same width!

The fronts are called out at  $\frac{7}{8}$ " over in net length. The reason for this is it allows the same (finger) depth of the cut as used on the drawer sides, but most importantly it provides extra support material when machining the plug holes – which are very near the edge with the grain in the weak position.

To get started on the finger joints, first lay out the actual (remember the extra length of the drawer fronts) location of the finger joints.



**Delicate Operation.** The fingers in the drawer fronts are left long to avoid breakage when chopping mortises for the smallest plugs.

Now, set up a table-saw sled with a dado head and a clamped stop block to cut the  $1\frac{1}{16}$ " wide by  $1\frac{3}{16}$ " deep finger in one pass. Practice using scrap material, make the cut and check for accuracy. Next turn the scrap over



**Getting the edge.** To sand and pillow the proud fingers, first mark the limits of the pillowing with sharp pencil using the scrap drawer front



**Down to the line.** With #120 grit and a sanding block, bevel the edges to the line at a 45° angle.



**Soft Finish.** With a piece of folded #120-grit sandpaper, shape the pillow effect on the end of the fingers removing the previous bevel but not going beyond it. Finish off the short edges with your thumb backing up the sandpaper. Run through the grits refining the pillow shape along the way and ending at #320 grit.



**Results from careful work.** After beveling, test the fit before assembling the finger joined drawer.

and make the same cut only referenced from the opposite edge. Once the setup is correct, run the actual drawer sides.

Setting up for the drawer front fingers will involve more trial and error and most likely use much more scrap material. Reset the dado head to about  $1\frac{3}{16}$ " wide (or so). Use the completed drawer side to move the stop over for the first cut in the drawer front. Referencing the cut from both sides and using scrap material, make the cut. With the band saw, waste out the material in between and test-fit to the drawer side.

Repeat this process until there is a successful test fit. Run three or four extra scrap pieces on this setting. They will be needed for setting up the subsequent step. Again using the completed drawer side as a guide reset the stop to cut the material in the middle away. Make the cut on scrap. This cut is like the previous cuts in that it is run twice and referenced off both edges, although this time there will be a small amount of material left in the middle.

On the test pieces, remove the material in the middle using the band saw – then test the cut by fitting it to the drawer front. After a successful test is made, run the drawer sides but remove the material in the middle by moving

the stop over after all the parts have been run. Lay out all the plug holes at this time.

The sides can be machined as before, but because the fronts are smaller than any available hollow chisels, they must be drilled, then squared up with a regular chisel. When done, trim the drawer fronts down to their final size so the fingers are flush with the outside face of the drawer sides.

Next, route a  $\frac{1}{4}$ " x  $\frac{1}{4}$ " groove on the inside of the sides and fronts referenced  $\frac{1}{4}$ " from the bottom. On the fronts this can go all the way through but on the sides it must be stopped or else it will pass through the front of a finger.

With the joinery completed, cut out the drawer bottom and test-fit it. If all fits well, sand all the parts to #220 grit and glue one drawer side to a drawer front. Instead of relying completely on clamps, the top two peg holes of the drawer side fingers can be used to screw the sides to the front (the bottom peg hole is too close to the drawer groove)

Clean up any excess glue with water and a series of toothbrushes ending with a clean brush and water that does not leave any glue residue. Use clamps to bring the glue-up back to square if necessary. Glue the opposing side to the front then slide the drawer bottom in



**Fence matches handle.** A curved piece of MDF is employed as a fence on the router table to guide the bowed handle over the core box bit, relieving the back of the pull.

place and attach the other drawer front with glue and screws.

Use pieces of veneer as shims (on the bottom side) to tighten the  $\frac{1}{4}$ " bottom in the groove. Check the assembly for square and flat and adjust if necessary.

### Drawer Pull Fabrication

One of the thrills of seeing a piece of Greene & Greene furniture in real time is discovering the many small details that aren't apparent at a casual glance or in a photo.

Most of these details are very subtle. If one is missing you may sense something is not

right, but probably can't put your finger on it. A good design should present the viewer with pleasing proportions and a strong focal point. An exceptional design will hold back some of its finer details for a closer look. This piece whether it was designed by the Halls or the Greenes has these subtle details. Its bow front drawer pull is one such detail.

At a casual head-on glance, the drawer pull appears to be flat, just like any other pull. But as you can see in the photo of the original piece, the pull is bow shaped. A pull needs enough depth so fingers can reach behind and grip. A pull that is lower in profile may be more pleasing to the eye but not to the hand.

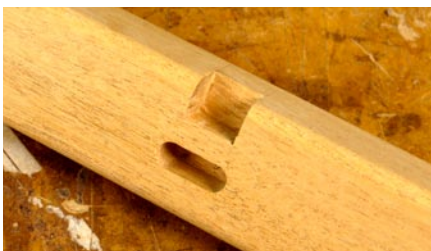

**Notch for the shelf.** The router jig pictured below and at right is used to produce the notch.



**From below.** The slot made in the jig is used to visually line up the jig with the router bit.



**One way only.** The router base is trapped by the fences so that it will only move in to the leg.

One clever solution is to make a pull that is low in profile at the ends but gradually gains depth towards the center. This is not merely the answer to a form-versus-function problem. The exceptional detail also solves some critical functional criteria as well, giving it the best of both worlds; a form that truly follows function. And in this case the form is more pleasing.

As usual, details such as these involve more work and often a bit of head scratching. In this case my shop assistant, Graham Jackson, did the head scratching for me. After machining the pull to its blank overall size, layout and machine the ebony plug holes. In the center of the holes pre-drill for #8 wood screws.

On a piece of MDF, use a bending stick to layout the curve in the bow front. The concave side will become a router table fence and the convex side will become the routing template for the pull itself. These parts must mate together well. After band sawing to the line, attach sticky back #60-grit sandpaper to one of the parts.

Run the parts together to even out the mating surfaces. Change the sandpaper to the other part and again the run the mating surfaces together. This process should produce two well mated surfaces. After routing the bow shape in the pull, set the router table up with a  $\frac{3}{4}$ " diameter core box bit and the concave portion of the MDF as a fence. Set the fence back  $\frac{3}{8}$ " from the bit. Lower the bit to take a very small cut and commence running the pulls. Raise the bit over several passes until the needed depth is achieved. Move the fence back until enough material is wasted to clear the back of the pull at its center point.

Once the bow is formed run a  $\frac{3}{16}$ " radius around the face. With #80 grit knock down the square edge on the back side. Continue with the sandpaper until a full radius is formed similar to the radius on the face side. Use a spindle sander to form the finger relief on the back sides of the ends. Before attaching the pull with four #8 X 1" wood screws make sure the pull and drawer front are fully sanded to #220 grit, giving it the best of both worlds: a form that truly follows function. **PW**

---

*Darrell Peart specializes in furniture in the style of Charles and Henry Greene, and is author of "Greene & Greene: Design Elements for the Workshop" (Linden). A photo gallery of his work and the book are available on his web site: [furnituremaker.com](http://furnituremaker.com).*